



Dr. Dave Irvine- Halliday. Credit Rolex / Xavier

## Solid State Lighting for Human Development

### Light Up The World – Update (2001 – 2002)

---

**Ken Robertson\*   Stewart Craine\*\*   Dave Irvine-Halliday\*   Roger Stone\*\*\***

\*University of Calgary & LUTW, Canada   \*\*Curtin University of Technology & LUTW, Australia

\*\*\*Fernbank Electronic Systems Limited, Stittsville, Canada

**[www.lutw.org](http://www.lutw.org)**



Demonstration of an LED lamp in a home in Sri Lanka. Irvine-Halliday's idea is to light rooms only for specific tasks. Rolex / Xavier Lecoultre

## **Solid State Lighting for Human Development**

### **Introduction**

Light Up The World Foundation (LUTW) is the world leader in utilizing solid state lighting (SSL) technologies and processes to enhance the quality of life of the poor in the developing world. LUTW was founded in 1997 by Dr. Dave Irvine-Halliday with the explicit goals of using donor and local Social Entrepreneurial means to bring safe, healthy, reliable, environmentally friendly and affordable home lighting to the one third of humanity that lives virtually in darkness as soon as the sun goes down - and especially so that children, particularly females, could study in the evenings. The truly incredible and unrelenting worldwide demand for LUTW's assistance far, far exceeds its capacity to respond meaningfully at present. To date LUTW is active in over a dozen countries. LUTW has set the standards and is committed to raising the quality of SSL in the developing world home with every improvement in the technology.

Light Up The World was the first humanitarian organization to introduce this liberating technology to homes in the developing world and we continue to be the only one globally active in spearheading efforts to introduce solid state lighting to those most in need.

*“Good God John, a child could read with the light of a single diode”* Canada 1998



Women tending fire in Sri Lanka with LED lamp in background. Rolex /Xavier Lecoultre

## **Light Up The World is Illuminating Lives**

LUTW has become the platform to accelerate the early adoption of SSL as a community development tool worldwide. The ability to read and study after dark has an enormous impact on the social, economic and physical lives of those with little opportunity. Not the least of these benefits is the improvement in education of children and women in areas where poverty and illiteracy walk hand in hand. The ability to operate a cottage industry by night using fixed or mobile task lighting helps people earn a modest living. It is not just about the provision of light – a very precious commodity we in the developing world may take for granted. Our processes reorient development strategies toward the creation of enterprise, enhanced income and gender equity, health, safety and protection of the physical environment. This is not fanciful thinking – It has been our experience. Our aim, with some real hope, is the realization of potential for a great many underprivileged people.

*“This is the first time in the lives of my children that they could read at night”*

Sri Lanka 2001

**Translation of Plaque at Pukunutenna, a LUTW village in Sri Lanka:**

*With the thought “Let not a ray of sunshine falling on our roofs go to waste without being of service”, this community based solar and wind powered renewable energy system signifying the interdependence between the village and the city, was commissioned on 31<sup>st</sup> December 2001 and inaugurated by Ven Pannananda Thero of the Damwelodiya Temple.*



Nine-LED lamps designed by Irvine-Halliday's team and distributed in rural Nepal, as well as in Sri Lanka and India. Rolex / Xavier Lecoultre

## Market Development - Small Solutions for Large Problems

The opportunities in the developing world to harness high brightness LEDs (HBLED) and solar photovoltaic (SPV) technologies are vast. According to the World Bank 67% of the rural population in developing countries are without electricity today. A third of the world's population must rely on fuel-based lighting, which is costly in human terms even if reliable supplies can be procured. Not only are fuels in the form of kerosene, candles and scarce wood a primary expense for the rural poor, the toll exacted on human health, safety and the environment is enormous. In addition, oil import dependency drains scarce foreign exchange of governments in developing countries and the costs of electric generation, transmission and distribution to rural regions are extraordinarily high. LUTW offers a small solution to these large and pressing problems.

By introducing this system to countries in the developing world through projects and local entrepreneurial means, the LUTW Foundation initiates and accelerates the use of low cost, practical, solid state lighting systems in poor villages with little realistic prospect of affordable electrification. Through volunteer efforts and by providing high-profile advocacy for solid state lighting systems, the LUTW foundation has taken pioneer applications to a number of developing world countries. While benefiting the very poor LUTW's activities have attracted international awards, the attention of the media, NGOs, governments, development banks and various social and commercial interests. Indeed, LUTW's humanitarian work in the developing world is helping to seed demand for, and raise awareness of, the practical use of WLEDs for home, task and mobile lighting on a broad scale to a number of market segments in what may very well be a "trickle up" approach to the development of markets for WLEDs and ancillary technologies in non-traditional areas.



Muni Raj (left) of Pico Power Nepal with LED lamps that his firm sells at socially responsible, affordable prices. Rolex / Xavier Lecoultre

## **Social Entrepreneurship & Human Development**

Micro enterprise development is a fundamental component of LUTW's philosophy and approach. Conventional project delivery combined with a local business start-up meets the twin demands of reaching a very poor segment of the population while simultaneously reinforcing entrepreneurship as one of the most effective and sustainable forms of local development. LUTW purchases the assembled equipment and services from a local business start-up for most area projects. LUTW installs equipment at no cost to the very poor but does require a high degree of initiative and mobilization among the community organizations to be a candidate. A LUTW assisted business start-up ensures that installation, maintenance and support services continue to replicate after our initial projects have seeded the technology. Project delivery by teams of outsiders alone simply cannot reach, in a substantial form, the 2 billion people without adequate access to affordable light.

Developing local business interests with modest commercial incentives has the ability to continually replicate our project successes in many areas of the world. LUTW does not, and will not, own any of these companies but will assist in their startup, development of expertise and sustainability.

*“A foreigner has come and made Thulo Pokhara heaven”* Nepal 2000

## Establishing Businesses

There is no incompatibility whatsoever between establishing local companies or facilitating their development, and LUTW's mission. Humanitarian work, meaningful livelihoods and good business practices form the principle of Buddhist Economics. Pico Power Nepal (PPN), whose startup capital was gifted by Dave & Jenny Irvine-Halliday, is a case in point. Modest commercial incentives and the owners' social ethic have combined to create opportunities for all involved. PPN operates as an independent Social Enterprise that enhances income for the family operators and presently provides full-time employment for two technicians. Certainly, community members benefit as they can purchase lighting systems and receive installation and warranty services at a price that typically has a payback period of much less than 2 years when compared to substandard and unhealthy fuel sources such as kerosene. There is every reason to believe that this more holistic approach is the model for the developing world to follow.

Most, if not all, of us would like to believe that job satisfaction is high on our priority list and if this is indeed so then there is an enormous degree of satisfaction, joy and humility to be gained from working with or for companies which operate on a social entrepreneurship basis for the overall good of humanity. The goal of any company must be sustainability, to remain in business, but the 'bottom line' must not simply be about maximizing the pure cash profit, just as the environment must always have a place on the company balance sheet.

## Forging Industrial and Humanitarian Partnerships

From the very beginning one of the primary objectives of LUTW has been to establish 'special' humanitarian-entrepreneurial relationships with manufacturers of White LEDs, Solar Panels and Batteries in order to drive down the overall cost of SSL systems to the developing world villagers.

The first part of this '**holy trinity**' has been accomplished with the formalization of our relationship with LumiLeds and we are actively pursuing similar relationships with various manufacturers of solar panels and batteries.

As a humanitarian organization whose public works and advocacy effectively promotes and seed markets for solid state and ancillary components, LUTW is looking for industrial partners to provide preferential terms and arrangements. In our master plan, supply chain relationships with manufacturers are essential to dramatically lower system costs and to step up the formation of small 'Pico Power' companies, totally owned and operated by local entrepreneurs.

***“We always pray to God for you and your family for sending us the beautiful gift of light.”*** St. Alphonsus Social & Agricultural Centre – Kurseong, West Bengal, India 2001

## LumiLeds

Our partnership with LumiLeds is the key component of our product strategy. By incorporating the world's most advanced commercially available 1-watt device into our reference designs, LUTW can source *Luxeons* to local business and social organizations in developing world markets worldwide.

The next step in our product strategy is the inclusion of prospective battery and solar panel manufacturers and distributors into our supply chain at preferential prices to dramatically reduce costs thereby increasing the affordability threshold for those with very low levels of disposable income. Batteries for example are one of our highest cost components. If LUTW could enter into an arrangement to pay bulk prices for small lot purchases, the price of batteries in our lighting systems could be more than halved.

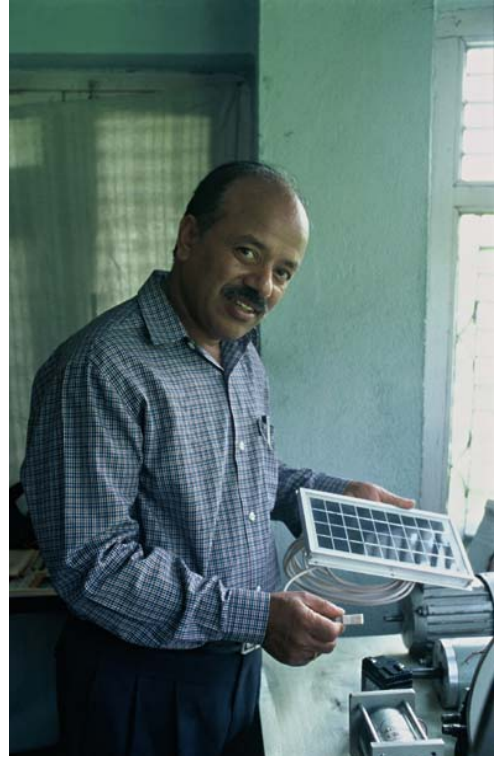

Muni Raj, a solar energy expert. Rolex / Xavier Lecoultre

## Demand for Services

The demand for LUTW's services is overwhelming and far outstrips our ability to respond. To increase the capacity to deliver, LUTW is securing additional partnerships with strong, capable and committed in-country social organizations to assume effective coordinating and administering roles. The Centre for Rural Technology (CRT) in Nepal is one such organization that coordinates our activities in conjunction with the development of electrified ghattas (watermills) and other public works. In Sri Lanka LUTW is working with a philanthropist engineer (Lalith Seneviratne), the Faculty of Engineering at the University of Moratuwa and the Agricultural Development Authority, to light up three remote villages.

Our prospective commercial partner in Sri Lanka, Ceyenergy, has the resources and reach along with a Grameen Bank affiliation to assemble, install, train, service and warranty SSL systems as well as extend micro credit to rural communities. What is more, local business partners such as Ceyenergy, Pico Power Nepal, and Geetanjali Solar Enterprises in India not only have the capacity to innovate beyond LUTW's reference designs and provide technological improvements, but also are actively encouraged to do so.

LUTW is fast evolving into a facilitating organization that effectively partners with a cadre of international/regional/local organizations that have the expertise, reach and resources to execute our projects on a large and continuous scale. In conjunction with Rotary clubs in Calgary and Calcutta, LUTW is planning an ambitious large-scale multi-stage project

involving up to 1500 villages in India over the next several years. This project will require the extensive in-country resources, international funding and project management expertise that Rotary and few others can muster and manage. LUTW will assume lead planning and training roles while Rotary will deploy its vast corps of skilled and experienced regional and local volunteers to hook up with village level microcredit institutions and to manage and administer all ground level networks of participation. The parallel development of LUTW as an organization will allow us to facilitate projects in multiple countries through the mobilization of our delivery partners. As a result of our many evolving industrial and social partnerships, LUTW expects, by the end of 2002, to see the average one time cost to light a typical home decrease from \$60 US to approximately \$35 US.

LUTW through its work in Sri Lanka has attracted the attention of the World Bank and its accredited commercial partners. The World Bank along with the national government is anxious to electrify large areas of Sri Lanka off-grid, using village owned micro generators and solar home systems. Up until now conventional solar home lighting systems have proven prohibitively expensive for all but the urban well off - residential backup systems. LUTW demonstrated to the World Bank office that Luxeon lighting systems can meet the need at a quantum price reduction that poor remote villagers, many of whom do not participate in the cash economy, can afford, especially if solid state lighting is granted inclusion for World Bank subsidies and microfinance programs.



Outside a home that will be lit using solar power; Irvine-Halliday discusses where panels should be installed. Rolex / Xavier Lecoulre

## **Micro Enterprise – A Pilot Project Aimed at Female Employment**

LUTW has long recognized the villager's need for mobile lighting and torches (flashlights) in particular. In the developing world they are near essential survival items. Despite their guarded use, families that do have torches may expend upwards of three D Cell batteries and countless rejected specification bulbs per week. Batteries and bulbs are a primary expense and put a strain on limited family incomes.

In response, LUTW has initiated a “D” Cell, solar powered, battery charging pilot project in the villages of Thulo Pokhara and Raje Danda in Nepal, specifically aimed at providing a sustainable income for women. The system will of course also charge “AA” and “C” cells if required. The business model provides women entrepreneurs with a 2.5 Watt solar panel, a battery charging control unit capable of charging 1 to 4 D Cells and five WLED torches loaned out on a rent to own basis.

Villagers will pay half the cost of a new primary battery to recharge their batteries and the income earned by the female entrepreneur will be used to pay off the capital cost of the torches and batteries.

Estimated payback is only 1 year for the entrepreneur while savings to community members involved in the pilot project is immediate.

## **Buddhist Economics**

Buddhist economics demands that all people involved in the business transaction are better off. The objectives of the pilot project are to demonstrate three significant benefits of WLED torches:

1. **Sustainable Livelihoods** – a microenterprise model can be introduced that provides sustainable income for women, or women’s cooperatives, while providing the superior benefits of solid state torch lighting to the broader community.
2. **Economic Savings** – Significant real savings accrue to village members over the near permanent lifetime of durable and rugged solid state torches.
3. **Environmental Impacts** – In Nepal, a country with over 24 million families, literally hundreds of millions of non-rechargeable batteries are discarded directly into the environment each year. The resulting pollution to streams, groundwater and fields threatens to be immense. The extended lifetime of rechargeable batteries can dramatically reduce the cumulative burden on the environment - even if they are not recycled!

## **Energy Efficient Driver Circuits for HBLEDs**

In order to optimize the size of the power generating unit, in many cases a solar panel, it is absolutely necessary to utilize the energy stored in the battery as efficiently as possible - especially when using a 12 Volt battery to power a 3 Volt Luxeon HBLED. There is also the requirement that we regulate the current flow to the Luxeon, with a high degree of reliability since the effective current is 350 mAmp.

This has been a challenging time for LUTW what with the almost paradigm shift away from the 20 mAmp Nichia White LED circuitry to that required by the 350 mAmp Luxeon. This has not been a trivial challenge especially as we had to allow for the full range of Luxeon forward voltages, flux outputs and color temperatures. In the near future there is little doubt that Luxeon Driver Circuit (LDC) chips will be available at minimum cost, but to the best of our knowledge, they are not yet in existence for our particular requirements. Though we have designed and built LDCs which will power up to three Luxeons in series we have, for the present, standardized on the one LDC per Luxeon design.

## **LUTW – Luxeon Driver Circuit Design Challenge**

Since one can always improve on a particular design, **LUTW is issuing a challenge to the Photonics Industry** and it is as follows:

Design a Luxeon Driver Circuit (Appendix) which meets the needs of LUTW **at a lower cost than the ones we have already designed**, keeping in mind that many thousands of these LDCs will in all likelihood be hand made in their country of use. LUTW must also be free to distribute the ‘winning’ circuit designs to any of its in-country LDC manufacturers.

## **Metrics for Solid State Lighting in the Developing World**

The challenge of how best to measure solid state lighting in a manner that reveals the practical relevance to human needs in the over-developed and particularly in the developing world, needs to be addressed with some urgency.

Many of the superior characteristics of White LEDs do not find form in traditional cost/effectiveness decisions. The challenge that LUTW faces is to find a mix of measures that can be relatively well understood by policy developers and decision makers to among other things, substantiate inclusion in development bank and government sponsored rural electrification and lighting programs.

The Luxeon vs. Compact Fluorescent Light (*CFL*) is definitely a case of “apples and oranges” in most metrics used today, nevertheless direct comparisons are made usually on the basis of lumens per watt and the cost of the light source. This of course totally ignores all the other remarkable characteristics of the Luxeon.

LUTW is making attempts (*appendix Table 1*) to clarify/establish metrics with which SSL systems may be judged in a developing world context particularly in regard to general usefulness, efficacy, ‘optical efficiency’, hardware costs, power generation requirements, effective system life and total energy used and its cost over that lifetime (*Life Cycle Analysis*).

Attention in the photonics industry needs to be directed to these areas, as the lack of well-understood and communicated metrics is a barrier to entry into non-traditional home lighting markets.

*“This project particularly appeals to me because it touches a very basic need that has huge ramifications for the quality of life. If there is no light, you can do nothing. The gift of illuminating a home brings almost incalculable benefits to the inhabitants of remote villages in the poorest parts of the world. Cutting-edge, simple technology is the hallmark of great science.”*

Baroness Susan Greenfield 2002

## **Carbon Reduction Emission Credits**

The international effort to reduce greenhouse gas (GHG) emissions under existing and evolving climate change mitigation mechanisms presents LUTW with an opportunity for additional revenues to help sustain our projects as it is possible to quantify the amount of fossil fuel and GHG reductions from our solid-state lighting systems.

Field survey results from Nepal, and discussions with experts [1, 2], lead to an estimated average kerosene consumption of 3.5 L/month/household, or 42 litres per household per year for home lighting. This is consistent with recent field data collected by LUTW in Nepal, Sri Lanka and India. Based on Mills' emission conversion of approximately 400 litres of kerosene per tonne of CO<sub>2</sub> released, it would take an average rural household 9 years to release one tonne of CO<sub>2</sub>. Considering RECs are worth approximately \$30/tonne of CO<sub>2</sub>, emission credits of approximately \$3/household/year may be earned through village lighting projects.

In determining the value of RECs it is essential that the entire energy conversion chain of kerosene from extraction, refinement, and transportation extended on up to the ultimate use has to be considered.

The Dutch government has recently started accepting submissions from developing countries for emission reduction projects through their CERUPT project. It is expected that similar programs will materialize in coming years so earning income from carbon credits is an emerging reality.

LUTW has investigated the market in emissions trading and the prospect of sales to selected commercial interests may help finance our solid state lighting projects or establish a fund that can distribute modest earnings to the rural community organizations themselves. This will be another area of active interest in 2003.

*“As the world’s resources diminish, Dr Irvine-Halliday’s imaginative application of new technology to help improve the lives of people in some of the poorest and most remote regions of the world is a very encouraging enterprise that kindles optimism in my heart.”* Mr. Fumihiko Maki, 2002

## Summary

The Light Up The World Foundation was the first humanitarian organization to introduce the liberating technology of solid state lighting to homes in the developing world and we continue to be the only one globally active in spearheading efforts to introduce solid state lighting to those most in need. Our biggest challenge is to meet our market, which is unfortunately enormous, in a substantial way. To do this LUTW is focusing on partnerships with industry and social organizations to: 1) drive down the cost of our solid state lighting solutions through innovative designs and preferential supply chain relationships and 2) to plug into effective delivery mechanisms that can coordinate and administer LUTW affiliated projects worldwide.

The rewards of LUTW's work for its founder, Dr. Dave Irvine-Halliday is beyond words and has become an all-consuming passion. Dr. Irvine-Halliday would like to recognize his executive management team for their expert contributions and particularly for their dedication and the vast amount of time they have freely provided to move the organization forward to its next stages of development and to ensure the continued success of the Light Up The World Foundation. ***Many Thanks.***

***“It has been true since the beginning of the industrial revolution that technology alone solves nobody’s problems unless someone clever and with foresight comes along to apply it where needed and wanted. Dave Irvine-Halliday’s project to bring efficient and affordable lighting to poor rural villages in developing countries is bolstered by using batteries that recharge with a simple application of human energy. Dr Irvine-Halliday can indeed light up the lives of those in rural homes in developing countries.***

Dr. Neil De Grasse Tyson, 2002



### **A Fundamental Belief**

*It is a fundamental obligation for we in the ‘developed world’ to assist those in the ‘developing world’ to raise their standard and quality of living, by their own efforts and in a manner which they choose – it is also our privilege.*

*The Light Up The World Foundation can play its part in easing the daily struggle and help raise the level of education, health and prosperity throughout the developing world, and I sincerely believe that we can make a difference – we truly can.*

*Let us together, in this new millennium, light up the world.*

*Namaste,*

*Dr. Dave Irvine-Halliday*

**LUTW** →  
**light up the world**  
foundation

## References

1. S. Craine, W. Lawrance and D. Irvine-Halliday, “Pico Power – Lighting Lives with LEDs”, AUPEC 2002 Conference.
2. E. Mills, “Global Lighting Energy Use and Greenhouse Gas Emissions” Lawrence Berkley Laboratories, Unpublished draft report, May 2000.
3. D. Irvine-Halliday and S. Craine, “Does the Overdeveloped World Appreciate the Win-Win-Win Opportunities for HBLEDs in the Developing World? ”, INTERTECH Light Emitting Diodes 2001 Conference.
4. R. Stone, Luxeon Driver Circuit Design & Challenge, Sept 2002.

## APPENDICES

### The cheapest Luxeon Driver Circuit?

#### Introduction and challenge

Our project to bring low-cost lighting to the poor (and others) in the Third World is described on our web site, <http://www.lightuptheworld.org/Pages/Home.htm>. Briefly, we want to use the new, bright, efficient white LEDs to provide lighting at low power consumption, often from batteries that get recharged by solar panels, windmills, pedal generators, micro-hydro, and the like.

We believe that we can bring light into the lives of millions of people, to allow children to learn, to reduce burning of kerosene with its attendant dangers and health problems, and a whole host of other benefits.

For this, we needed a very simple switch-mode regulator as an efficient interface between a 12 Volt bus and the white LED. No integrated circuit appeared to exist that would directly do this job, cheaply, because the LED requires a regulated current rather than a regulated voltage.

**The circuit described below is crude, but quite efficient and inexpensive. We challenge designers to drive the cost down further: do it not just to beat us, but also to help light up the world!**

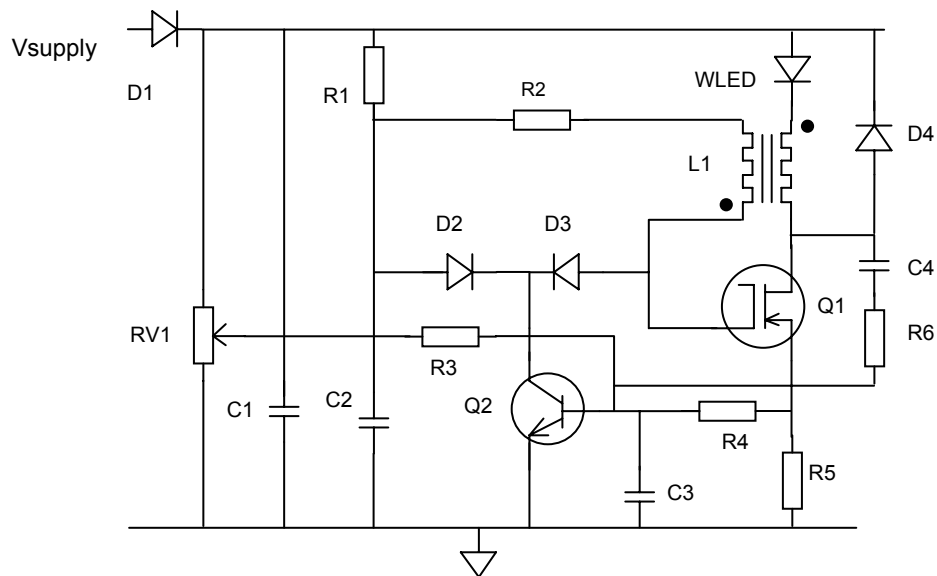

## Operation of the circuit

The circuit is an adaptation of the old blocking oscillator. It functions as follows:

1. Start with Q1 and Q2 both off. R1 charges C2 until Q1 starts to conduct. Positive feedback via the feedback winding on L1 causes Q1 to switch on fully and quickly.
2. With Q1 on, current builds up in the main winding of inductor L1. When it reaches about 0.45A, voltage across R5 causes Q2 to conduct. Spike filter R4-C3 prevents premature turn-on of Q2. Via D3, Q2 clamps the voltage on Q1 gate, and Q1 comes out of the switched-on state.
3. Positive feedback via L1 again reinforces the switching action and Q1 turns off fully and quickly. As the voltage on Q1 drain rises, a short transient of current in C4 and R6 keeps Q2 switched on for long enough to discharge C2 and reset the timing cycle. When the current dies out in C4-R6, Q1 turns off.
4. Go back to (1).

RV1 provides dimming. As the wiper moves towards the supply rail, it pulls up the base of Q2 and causes Q2 to turn on at a lower level of current in R5. Dimming is important so that people do not have to run the light at full power, for example when it is wanted only as a night light.

A simple circuit using a 10-cent dual op amp can provide two ancillary functions that we think are important: limiting the temperature of the white LED, and limiting battery discharge. That circuitry is not shown here because it does not relate to the purpose of this article.

## Some comments on the circuit

### Cost

Using typical pricing for the parts bought in large quantities, we think they amount to less than a dollar (US) not including the pot and the inductor which at time of writing are being sourced, and which in any case would be common to any other design and need not be included in any comparison.

### Operating frequency

Operating frequency is a broad compromise. We want to save on the cost of L1 (by using a high frequency) but under a certain size the cost will not drop much. Plus, too high a frequency will increase switching losses and could increase EMI: the other item that technology has brought to the poor is transistor radios, and they won't thank us for interfering with them.

The operating frequency will vary somewhat with the characteristics of Q1 and to some extent Q2, and with tolerances of passive components. This should not matter. The peak current is determined by R5 and the base-emitter voltage of Q2 which will be fairly consistent, and current decays from that peak. If the inductance of L1 is high enough to limit decay to a reasonable proportion of the peak current, the average current in the WLED is not much affected by the operating frequency.

In any case, high accuracy is not at issue here. The user controls brightness and will be encouraged to use only what is needed, to conserve energy.

### Current sensing

The half-Volt drop across the current sensing resistor R2 only occurs when Q1 conducts. So it effectively subtracts from the battery voltage, resulting in about 4% loss. Most of the time, the current circulates in the WLED and the freewheeling diode D4.

The reduction in base-emitter voltage with rising temperature will reduce current, which is acting in the right direction, even if temperature limiting were not included.

The safety diode D1 in series with the battery also incurs about 4% loss, but this may be preferable to the consequences of accidentally reversed connection to the battery, that could so easily occur.

### **The dimming control**

It may be necessary to take care that users cannot set RV1 to the very top and shut off the WLED, then conclude that the circuit is not working. On the other hand, a user's first action if the light did not illuminate would naturally be to crank the brightness up. RV1 could actually function as an on-off switch, at the cost of a little battery drain in the off state.

Note that the most common failure of a potentiometer is open wiper, and this would cause the regulator to default to full power output. At least the user gets some light.

### **Conclusion**

We hope that one or more IC makers will soon design and market IC's that embody all the functions needed to drive a white LED from a battery, dim it, limit temperature and battery discharge, and do whatever else may appear useful.

The power-handling portion could take the form of a synchronous buck regulator like those used for low-voltage supplies, in which FETs carry the current both paths: no more freewheeling diode, the major source of loss in our circuit. And of course an IC can do current sensing at a very low voltage drop, or even use the resistance of the FET itself. The result could be a very efficient driver. Maybe even sufficiently efficient (try saying that three times quickly) to include thermal sensing for the white LED right on the driver chip without incurring excessive error from the dissipation in the chip itself.

Another possible feature: circuitry to sense capacitively the position of a metal vane, and use this to control brightness – we eliminate the cost and failure rate of the potentiometer. Now we really have something!

But maybe manufacturers will only do that when there are millions of people using white LEDs to light their humble homes. If this circuit gets us to that point, it will have served a good purpose.

And the IC will have to beat its price!

**Table 1**

**Light Source Comparison of CFL & Luxeon Lamps over 50,000 hours**

	<b>Bulb (25W)</b>	<b>CFL (7W)</b>	<b>Luxeon (1W)</b>	<b>Kerosene wick</b>
Lamp cost \$US	1	<b>5</b>	<b>10</b>	\$1
Lumens Output	250	<b>250</b>	<b>40</b>	10
Lamp life (hours)	1,000	<b>6,000</b>	<b>50,000+</b>	5,000
<b>Lamp Lumen-hours per \$</b>	250,000	<b>300,000</b>	<b>200,000</b>	50,000
Fuel cost*	1	<b>1</b>	<b>1</b>	0.25
Lamp consumption**	25	<b>7</b>	<b>1</b>	0.05
Lifetime energy***	1250	<b>350</b>	<b>50</b>	2500
Energy cost \$	1250	<b>350</b>	<b>50</b>	625
<b>Total system cost (Lamp + Energy) \$</b>	1300	<b>392</b>	<b>60</b>	635
<b>System Lumen-hours per \$</b>	9,615	<b>31,888</b>	<b>33,333</b>	787
<b>Total system cost per lumen \$/lm</b>	5.2	<b>1.57</b>	<b>1.50</b>	63.5

\*\$/kWh for electric lamps, \$/L for kerosene. Since LUTW normally uses only pico power systems all three of the electrically based lighting units were accorded the same fuel cost in order to make the comparisons realistic.

\*\*Watts for electric lamps, L/hour for wick lamp.

\*\*\*kWh for electric lamps, litres for kerosene.

**Summary of CFL & Luxeon lamp comparison over 50,000 hours**

1. CFL has a [6:1] advantage in total lumen output
2. system lumen-hr/\$ are virtually equal
3. total system costs/lumen are virtually equal
4. total system costs are [6:1] in favor of Luxeon
5. power supply for Luxeon smaller by a factor of [7:1]
6. Luxeon has at least a [8:1] lifetime advantage plus ruggedness
7. Luxeon has approximately a [4:1] optical efficiency advantage

The Luxeon does have many other advantages including being more environmentally friendly and a rapidly increasing efficacy.

# Luminous Efficiency Table

